



诚信
CREDIBILITY

专注
PROFESSIONAL

共赢
WIN-WIN



BOTONG 博通精密科技 (浙江)有限公司

Seamless
Stainless Steel Tubes

电话/Tel: 86-572-2112889

传真/Fax: 86-572-2112887

info@botometal.com

浙江省湖州市长兴县泗安镇南华山工业园新丰路7号
邮政编码: 313113
No.7 Xinfeng Road,Nanhuashan Industrial Park,
Si'an Town, Changxing County, Huzhou City,
Zhejiang Province,China.313113



公众号



Website

Manufacturer of Stainless Steel
Seamless Bright Annealed Pipes and Tubes

专注品质 Focus on quality and
jointly create the future.

共创未来



C O N T E N T S

I 公司简介 Company Profile

II 产品介绍 Product Presentation

III 生产流程 Production Process

IV 不锈钢管的四种表面形态 Four Types Of Surface Condition Of Stainless Steel Pipes And Tubes

V 规格尺寸 Specification Dimension

VI 产品材质及生产标准 Product Material And Production Standard

VII 主要标准尺寸公差对照表 Dimension Tolerances For Main Specification

VIII 表面粗糙度对照表 Surface Roughness Reference Chart

IX 产品检测项目 Testing Items

X 主要生产设备 Main Production Facilities

XI 检测设备 Test Equipment

XII 产品应用领域 Product Application Fields

XIII 配套产品 Outsourced Products

XIV 资质荣誉 Honors

XV 公司部分业绩 Company's Achievements



BOTONG

PRECISION TECHNOLOGY

(ZHEJIANG) CO., LTD

Company Profile

公司介绍

博通精密科技（浙江）有限公司始创于 2010 年，是一家位于湖州长兴专业生产不锈钢无缝管的企业。公司占地 18000 平方米，年产各类不锈钢无缝管 2000 吨。

博通精密追求科技进步，引进国内外先进的生产技术，重视科技人才的培养和产品研发，秉承博而有信，通则致远”的企业精神，不断升级产品工艺，已将主要产品范围扩大到各类高端精密管道，如精密气缸管、EP 母管、EP 管等，积极为终端客户进行配套。

Founded in 2010, BoTong Precision Technology (Zhejiang) Co.,Ltd. is a manufacturer of stainless steel tubes located in Changxing County, Huzhou City.

We have a facility of 18000 square meters, with annual output of 2000 tons for stainless steel seamless tubes.

BoTong pursues scientific and technological progress, constantly introduces domestic and foreign advanced production technology, attaches importance to the cultivation of scientific talents and the development of quality products.

Adhering to the enterprise spirit of "innovative ideas lead to the future", we have continuously upgraded our product technology, and have expanded our main product range to all kinds of high-end precision pipes, such as precision cylinder tubes, EP mother tubes, EP tubes, etc. which are active support to end customers.

2010年
创立于浙江省湖州市
It was founded in Huzhou, Zhejiang Province in 2010

致力于生产
BA管、EP母管等
不锈钢无缝管
Committed to the production of Bright Annealed tube, EP pre-material, and other stainless steel seamless tubes.

年产量达**2000吨**
The annual output reaches 2000 tons.

- Keep Improving 不断探索
- Sales & Service & Survey 专业团队，更好的服务
- Strict & Careful 细致严格的品质把控
- Make every tube by heart 用心做好每一支管

Product Presentation

产品介绍

作为专业的不锈钢无缝管生产厂家，博通可提供各类奥氏体不锈钢，双相不锈钢、镍基合金等材质的产品，如：TP304、TP304L、TP316、TP316L、TP321、TP321H、TP310S、HC22、Monel400、N6等。

同时，十多年的行业经验，使我们积累了大量优质的配套产品资源，我们还为客户提供配套服务，如：不锈钢管件等产品。

As a professional manufacturer of stainless steel seamless tubes, BoTong can provide all kinds of austenitic stainless steel, duplex stainless steel, nickel-based alloy and other materials, such as: TP304, TP304L, TP316, TP316L, TP321, TP321H, TP310S, HC22, Monel400, N6, etc.

We have accumulated a large number of high-quality supporting product resources with more than 10 years of industry experience, so that we can also provide customers with supporting services, such as stainless steel fittings and other products.

Products

产品类别

主营产品 Main Products

不锈钢BA管
Bright Annealed Tubes

不锈钢EP管
Electro Polished Tubes

不锈钢MP管
Mechanical Polished Tubes

不锈钢AP管
Annealed & Pickled Tubes

配套产品 Outsourced Products

不锈钢弯头
Elbow (BA,EP)

不锈钢三通
Tee(BA,EP)

不锈钢大小头
Reducer(BA,EP)

不锈钢端盖
Cap(BA,EP)

不锈钢阀门
Valve

Product Advantage

产品优点

影响不锈钢管性能的关键因素
The Key Factors

材质是否干净
Material Quality

热处理是否适当
Heat Treatment

表面是否细致
Surface

BOTONG'S Tubes Can Fulfill All These Requirements.

更强的热交换效率与耐久性
More heat exchange efficiency and durability

节能、更低的维护费用
Energy savings, lower maintenance costs

Production Process

生产流程

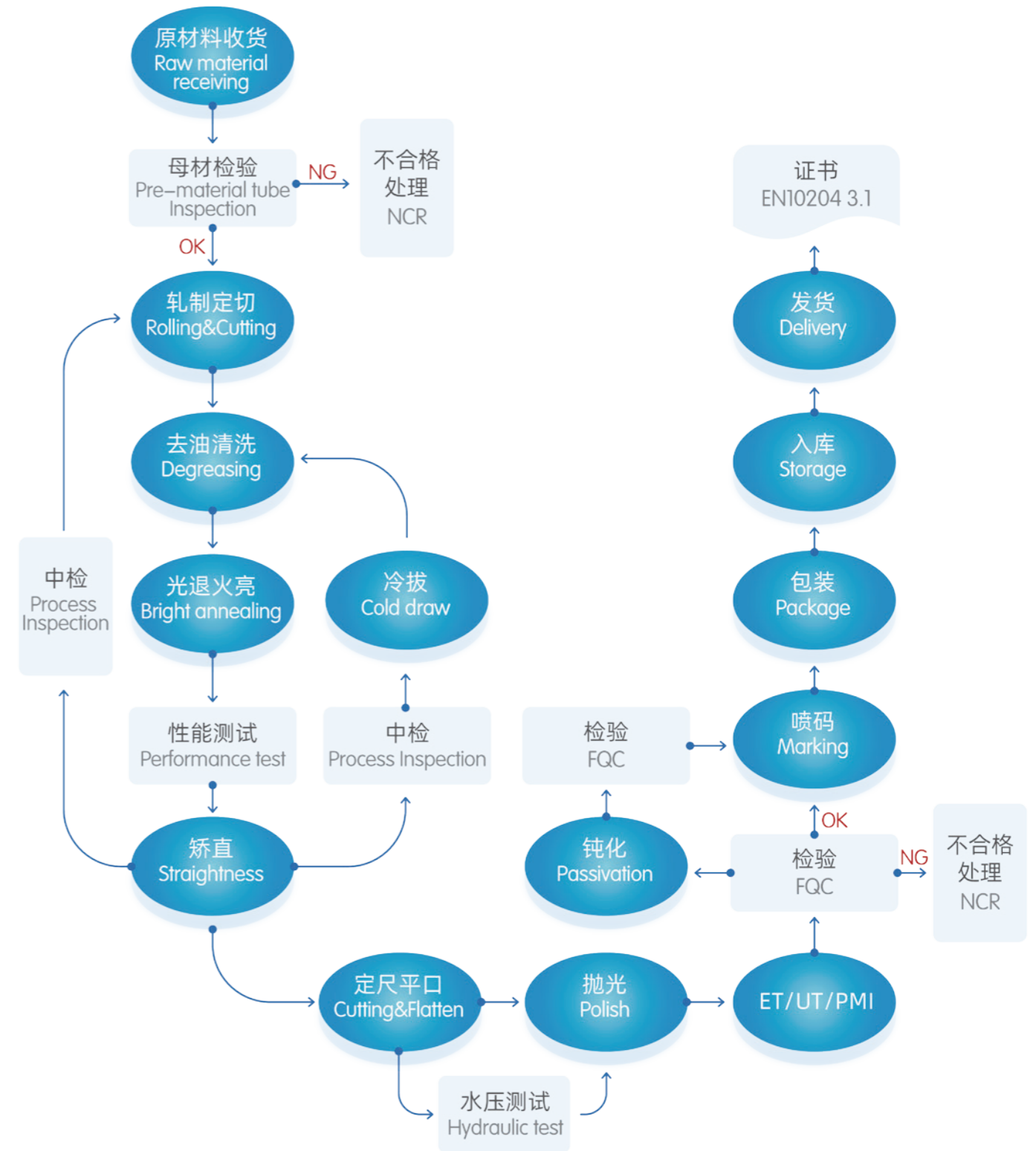

Four Types Of Surface Condition Of Stainless Steel Pipes And Tubes

不锈钢管的四种表面状态

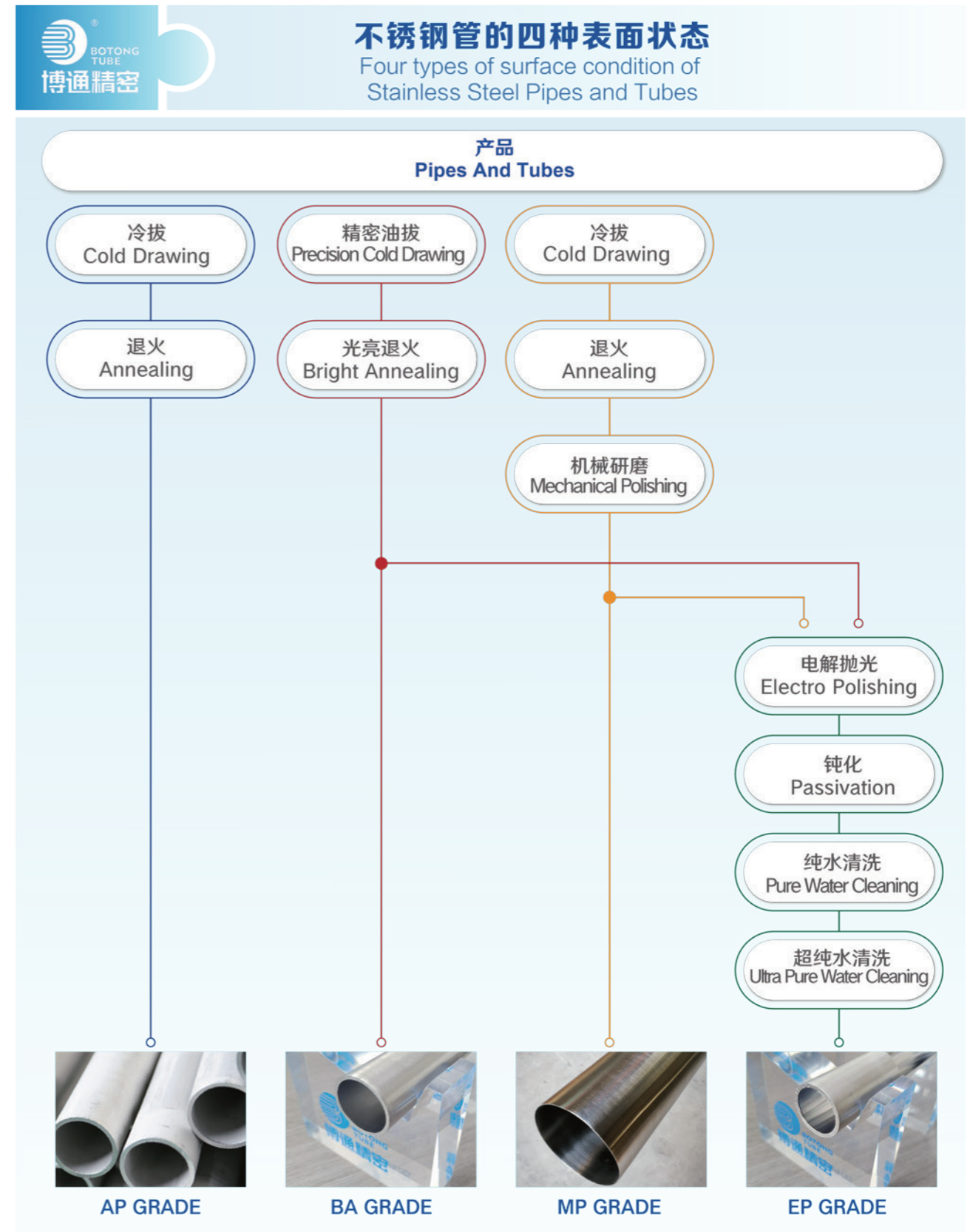

Specification Dimension 规格尺寸

Tube Size 尺寸		Wall Thickness 壁厚	AP 酸洗态	MP 机械抛 光态	BA 光亮退 火态	EP Pre EP母管	Length 单支长度
Size	Outside Diameter 外径						
1/8"	3.18	0.51					
—	6.00	1.00	•	•	•		
1/4"	6.35	0.89/1.00	•	•	•	•	
1/4"	6.35	1.24/1.65	•	•	•		
—	8.00	1.00	•	•	•	•	
—	8.00	1.50/2.00	•	•	•		
3/8"	9.53	0.89/1.00	•	•	•	•	
3/8"	9.53	1.24/1.65	•	•	•		
—	10.00	1.00	•	•	•		
—	10.00	1.50/2.00	•	•	•		
—	12.00	1.00	•	•	•		
—	12.00	1.50/2.00	•	•	•		
1/2"	12.70	0.89	•	•	•		
1/2"	12.70	1.00/1.24	•	•	•	•	
1/2"	12.70	1.65/2.11	•	•	•		
—	14.00	1.00/1.50/2.00	•	•	•		
5/8"	15.88	0.89	•	•	•		
5/8"	15.88	1.24	•	•	•	•	
5/8"	15.88	1.65/2.11	•	•	•		
—	16.00	1.00/1.50/2.00	•	•	•		
—	18.00	1.00/1.50/2.00	•	•	•		
3/4"	19.05	0.89	•	•	•		
3/4"	19.05	1.24/1.65/2.11	•	•	•	•	
—	20.00	1.00/1.50/2.00	•	•	•		
15A	21.70	1.65	•	•	•	•	
15A	21.70	2.80	•	•	•		
—	22.00	1.50/2.00	•	•	•		
—	25.00	1.50/2.00/2.50	•	•	•		

Customized
根据客户实际
需求定尺

Tube Size 尺寸		Wall Thickness 壁厚	AP 酸洗态	MP 机械抛 光态	BA 光亮退 火态	EP Pre EP母管	Length 单支长度
Size	Outside Diameter 外径						
1"	25.40	0.89/1.24	•	•	•		
1"	25.40	1.65	•	•	•	•	
1"	25.40	2.11/2.77	•	•	•		
20A	27.20	1.65	•	•	•	•	
20A	27.20	2.10/2.90	•	•	•		
—	28.00	1.50/2.00/2.50	•	•	•		
—	30.00	1.50/2.00/2.50	•	•	•		
1-1/4"	31.75	1.65	•	•	•	•	
—	32.00	2.00/2.50	•	•	•		
25A	34.00	1.65	•	•	•	•	
1-1/2"	38.10	1.65	•	•	•	•	
32A	42.70	1.65	•	•	•	•	
40A	48.60	1.65	•	•	•	•	
40A	48.60	2.80	•	•	•		
2"	50.80	1.65	•	•	•	•	
50A	60.50	1.65	•	•	•	•	

*除上述尺寸外，可根据客户需求进行定制生产

In addition to the above size, customization can be carried out according to customer requirements.

Unit: mm

Customized

根据客户实际
需求定尺

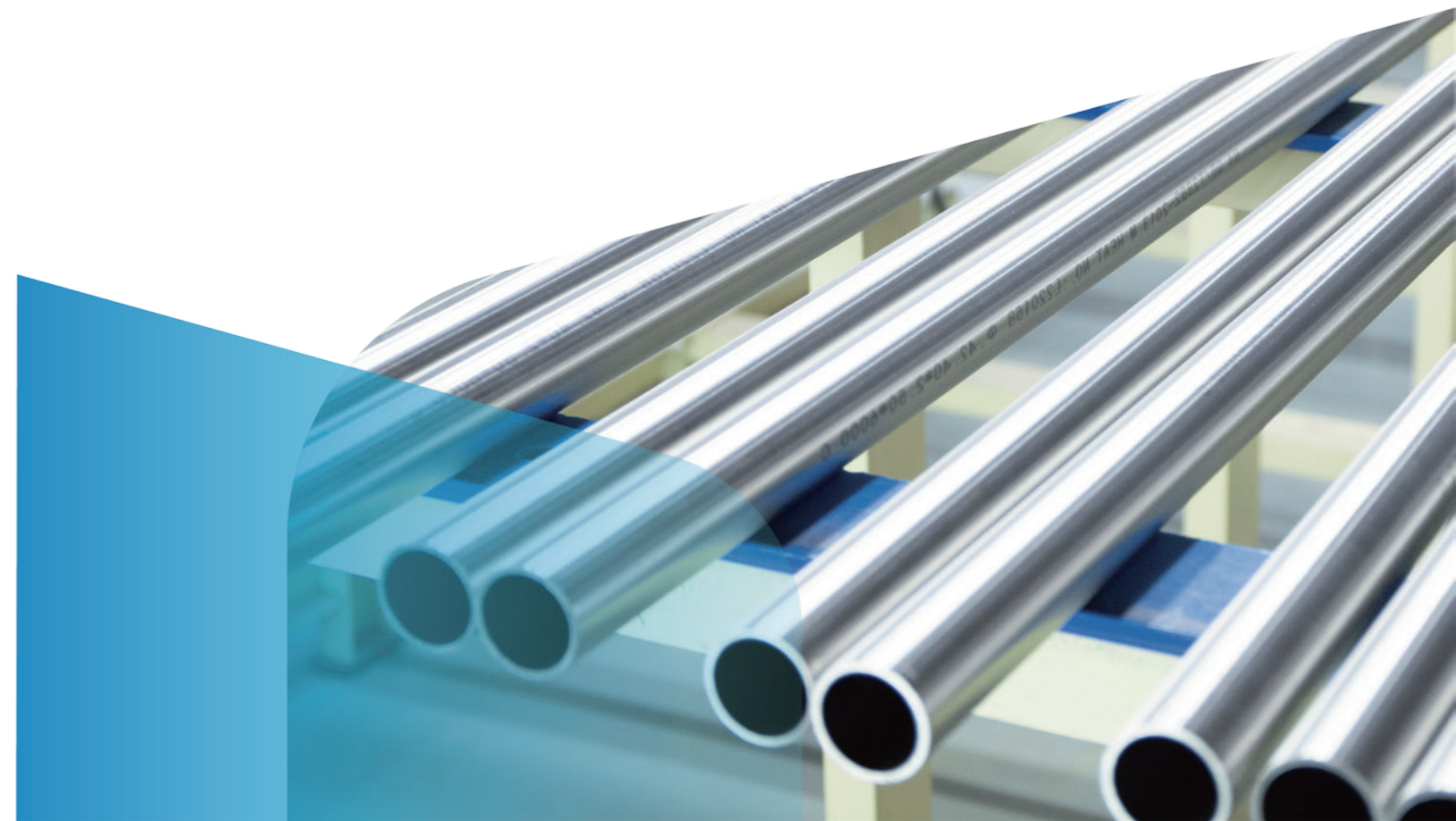

Product Material And Production Standard

产品材质及生产标准

主要产品材质及生产标准 Main Grade and Specification				
材质品类 Types	区域标准 Spe.Reg.	标准编号 Spe No.	标准名称 Specification	材质 Grade
不锈钢 Stainless Steel	美标 ASTM	A269	一般设备用无缝和焊接奥氏体不锈钢管 Seamless and Welded Austenitic Stainless Steel Tubing for General Service	TP304/L/H/N TP316/L/H/N TP321 904L
		A213	无缝铁素体和奥氏体合金钢锅炉、过热器和换热器管 Seamless Ferritic and Austenitic Alloy-Steel Boiler, Superheater, and Heat-Exchanger Tubes	TP304/L/H/N TP316/L/H/N/Ti TP321/H TP310S 904L
		A312	无缝和焊接奥氏体不锈钢管 Seamless, Welded, and Heavily Cold Worked Austenitic Stainless Steel Pipes	TP304/L/H/N TP316/L/H/N TP321/H TP310S 904L
		A789	普通设备用无缝与焊接铁素体/奥氏体不锈钢管 Seamless and Welded Ferritic/Austenitic Stainless Steel Tubing for General Service	S31803, S32205, S32750
		A790	无缝与焊接铁素体/奥氏体不锈钢管 Seamless and Welded Ferritic/Austenitic Stainless Steel Pipe	S31803, S32205, S32750

主要产品材质及生产标准 Main Grade and Specification				
材质品类 Types	区域标准 Spe.Reg.	标准编号 Spe No.	标准名称 Specification	材质 Grade
不锈钢 Stainless Steel	日标 JIS	G3459	不锈钢钢管 Stainless Steel Pipes	SUS304TP, SUS304HTP, SUS304LTP SUS316TP, SUS316HTP, SUS316LTP
		G3463	锅炉及热交换机用不锈钢管 Stainless Steel Boiler and Heat Exchanger Tubes	SUS304TB, SUS304HTB, SUS304LTB SUS316TB, SUS316HTB, SUS316LTB
	欧标 EN	10216-5	压力用途的无缝钢管-交货技术条件 Seamless Steel Tubes for Pressure Purposes Technical Delivery Conditions	1.4301, 1.4306, 1.4401 1.4404, 1.4541, 1.4845
	国标 GB/T	13296	锅炉、热交换器用不锈钢无缝钢管 Seamless Stainless Steel Tubes for Boiler and Heat Exchanger	022Cr19Ni10 (S30403) 06Cr19Ni10 (S30408) 022Cr17Ni12Mo2 (S31603) 06Cr17Ni12Mo2(S31608) 06Cr18Ni11Ti (S32168) 07Cr19Ni11Ti (S32169)
		14976	流体输送用不锈钢无缝钢管 Seamless Stainless Steel Pipes for Fluid Transport	022Cr19Ni10 (S30403) 06Cr19Ni10 (S30408) 022Cr17Ni12Mo2 (S31603) 06Cr17Ni12Mo2(S31608) 06Cr18Ni11Ti (S32168) 07Cr19Ni11Ti (S32169)
	镍基合金 Nickel Alloy	美标 ASTM	B163	无缝的镍和镍合金冷凝器和热交换管 Seamless Nickel and Nickel Alloy Condenser and Heat-Exchanger Tubes
国标 GB/T		B622	无缝镍和镍钴合金管材 Seamless Nickel and Nickel-Cobalt Alloy Pipe and Tube	N10276 (C276) N06022 (HC22)
		2882	镍及镍合金管 Nickel and Nickel Alloys Tube	N4, N6

Dimension Tolerances For Main Specification

主要标准尺寸公差对照表



标准 Specification	外径 O.D. (mm)		壁厚 W.T. (mm)	
	尺寸 SIZE	公差范围 PERMISSIBLE TOLERANCE	尺寸 SIZE	公差范围 PERMISSIBLE TOLERANCE
ASTM A312	10.29-48.26	+0.4/-0.8	All	±12.5%
	48.26-114.30	+0.8/-0.8		
	114.30-219.08	+1.6/-0.8		
	219.08-457.20	+2.4/-0.8		
ASTM A213	D<25.4	+0.1/-0.1	D≤38.1	. +20%/0
	25.4-38.1	+0.15/-0.15		
	38.1-50.8	+0.2/-0.2		
	50.8-63.5	+0.25/-0.25	D>38.1	. +22%/0
	63.5-76.2	+0.3/-0.3		
	76.2-101.6	+0.38/-0.38		
	101.6-190.5	+0.38/-0.64		
190.5-228.6	+0.38/-1.14			
ASTM A269	D<12.7	+0.13/-0.13	D<12.7	±15%
	12.7-38.1	+0.13/-0.13	D≥12.7	±10%
	38.1-88.9	+0.25/-0.25		
	88.9-139.7	+0.38/-0.38		
139.7-203.2	+0.76/-0.76			
ASTM A789	D≤12.7	+0.13/-0.13	All	±15%
	12.7-38.1	+0.13/-0.13		±10%
	38.1-88.9	+0.25/-0.25		
	88.9-139.7	+0.38/-0.38		
139.7-203.2	+0.76/-0.76			
JIS G3459	D<30	+0.3/-0.3	S<2	±20%
	D≥30	±1%	S≥2	±10%
JIS G3463	D<40	+0.25/-0.25	D<40;S<2	. +0.4/0
	40-50			
	50-60			
	60-80	+0.3/-0.3	D<40;S≥2	. +20%/0
	80-100	+0.4/-0.4		
	100-120	+0.4/-0.6		
	120-160	+0.4/-0.8		
160-200	+0.4/-0.6	D≥40	. +22%/0	
D≥200	+0.4/-1.6			
GB/T 14976	6.0-10.0	+0.2/-0.2	[0.5,1.0]	±0.15
	10.0-30.0	+0.3/-0.3	(1.0,3]	±14%
	30.0-50.0	+0.4/-0.4	S>3	-1.2
	D>50	±0.9%		
GB/T 13296	8.0-30.0	+0.2/-0.2	[1.0,3.0]	-1.2
	30.0-50.0	+0.3/-0.3	S>3	±10%
	D>50	±0.8%		



表面粗糙度对照表
Surface Roughness Reference Chart

普通名称 Common Name	Ra μin	Ra μm	ISO No.	USA Finish#
	2000	50	N12	
	1000	25	N11	
	500	12.5	N10	
Mill Plate	250	6.3	N9	#1
	125	3.2	N8	
Satin Sheet	70 Max.			#2
	40-60			
	63	1.6	N7	
	52			#3
Commercial#4	40-60			#4
3A Sanitary Finish	42 Max.			#4
	30-35			
ANSI #4 Sanitary	32	0.8	N6	
	30 Max.			#4
	20-30			
Biotech Finish	25 Max.			#4S
	20-25			
	15-20			#6
	16	0.4	N5	
	12 Max.			#7
	8-12			
	12	0.3		
	8	0.2	N4	
Mirror Finish	4-8			#8
Super Mirror Finish	<4			#8
	3-8			
Super Mirror Finish	4	0.1	N3	#8
	2	0.06	N2	
	1	0.025	N1	

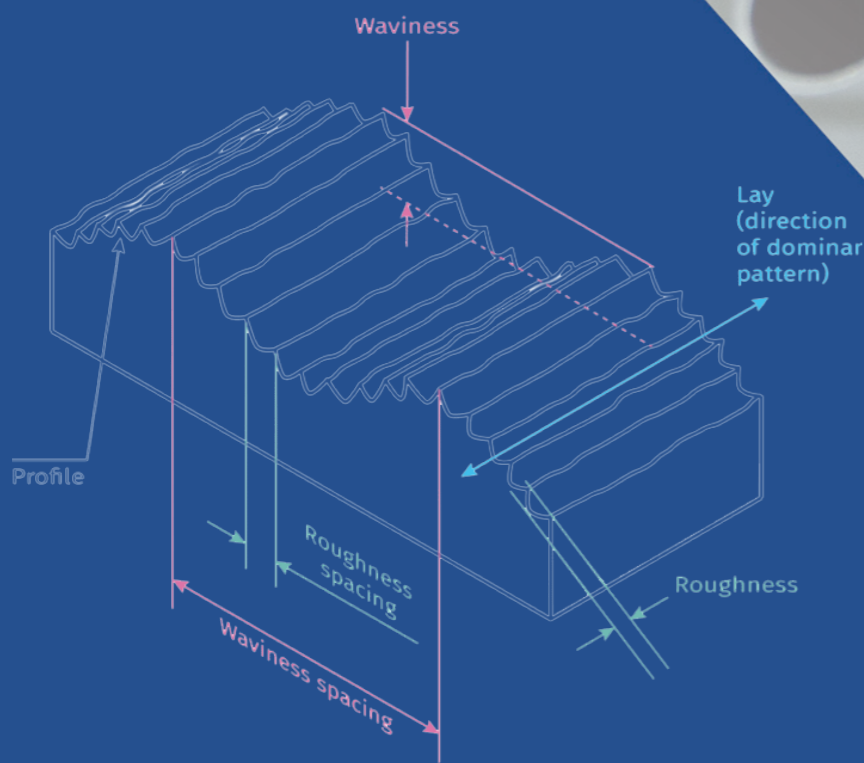

Surface Roughness Reference Chart

表面粗糙度对照表

Testing Items

产品检测项目

产品检测项目 Testing Items	类型 Type	检测标准 Testing Standard	适用范围 Range	取样数量比例 Sample Quantity	
材料鉴别 Material Identification	合金化学成分分析 Alloy Chemical Composition Test and Verify	非破坏性测试 Nondestructive Testing	E1476	标准 Standard	100%
强度 Toughness	抗拉强度 Strength of Extension	破坏性测试 Destructive Testing	A370	标准 Standard	按照炉批号取样 As per furnace batch
硬度 Hardness	洛氏硬度 Rockwell Hardness	破坏性测试 Destructive Testing	E18	标准 Standard	按照炉批号取样 As per furnace batch
	维氏硬度 Vickers Hardness	破坏性测试 Destructive Testing	E384	可选 Optional	按照炉批号取样 As per furnace batch
坚固性 Robustness	涡流检测 Eddy Current Test	非破坏性测试 Nondestructive Testing	E309/E426	标准 Standard	100%
	超声波检测 Ultrasonic Test	非破坏性测试 Nondestructive Testing	A688	可选 Optional	100%
泄漏与强度 Leak and Strength	水压试验 Hydrostatic Test	非破坏性测试 Nondestructive Testing	A1016	可选 Optional	100%
弯曲测试 Mechanical Properties Test	弯曲测试 Bending Test	破坏性测试 Destructive Testing	A370	标准 Standard	按照炉批号取样 As per furnace batch
	压扁测试 Flattening Test	破坏性测试 Destructive Testing	A370	标准 Standard	按照炉批号取样 As per furnace batch
	扩口测试 Flaring Test	破坏性测试 Destructive Testing	A370	标准 Standard	按照炉批号取样 As per furnace batch

产品检测项目 Testing Items	类型 Type	检测标准 Testing Standard	适用范围 Range	取样数量比例 Sample Quantity
尺寸 Dimension	外径、壁厚、直线度 OD,WT,Straightness	非破坏性测试 Nondestructive Testing	标准 Standard	100%
金相 Metallographic	晶间腐蚀 Intergranular Corrosion	破坏性测试 Destructive Testing	可选 Optional	按照炉批号取样 As per furnace batch
	晶粒度 Grain Size	破坏性测试 Destructive Testing	可选 Optional	按照炉批号取样 As per furnace batch
外观 Surface	目视检验 Visual Inspection	非破坏性测试 Nondestructive Testing	标准 Standard	100%
	粗糙度检测 Roughness Measurement	非破坏性测试 Nondestructive Testing	B46.1	可选 Optional

*以上检测项目的检测要求可按客户的实际要求进行调整。

The testing requirements of the above test items can be adjusted according to the actual requirements of customers.

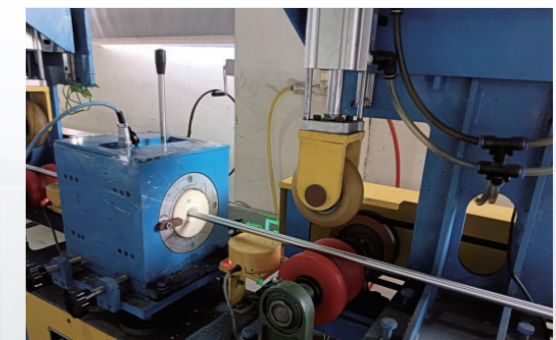

Main Production Facilities

主要生产设备



LG15 冷轧管生产线 *16

LG15 Cold Pilgered Line*16

LG20 冷轧管生产线 *8

LG20 Cold Pilgered Line*8

冷拔管生产线 *6

Cold Drawing Line*6

矫直机 *5

Straighten Line*5

自动切管机 *4

Auto Cutting Machines*4

退火炉 *4

Annealing Furnace*4

超声波清洗 *3

Ultrasonic Cleaners*3

Test Equipment 检测设备



Product Application Fields 产品应用领域



半导体 & 食品 & 医药领域

Semiconductor & Food & Pharmacy

- **主要材质** Grade: TP304L, TP316L, TP317L
- **钢管** Tubes and Pipes: BA & EP
- **应用** Applications: 高纯气体液体输送, 食品 - 医药生产设备, 半导体制造设备
High Pure Gas and Liquid Transportation
Manufacture Devices of Food, Pharmacy and Semiconductor



石油 & 化工 & 电力领域

Oil & Chemical & Electric Power

- **主要材质** Grade: TP304/304L, TP316/316L, 904L, 合金 600 和合金 625
TP304/304L, TP316/316L, 904L, Alloy600, Alloy625
- **钢管** Tubes and Pipes: BA & EP
- **应用** Applications: 化工、冶金、电力等领域的机械设备中; 油气输送、化工、电力等行业的高压管道系统
Manufacture Devices; High Pressure Piping System

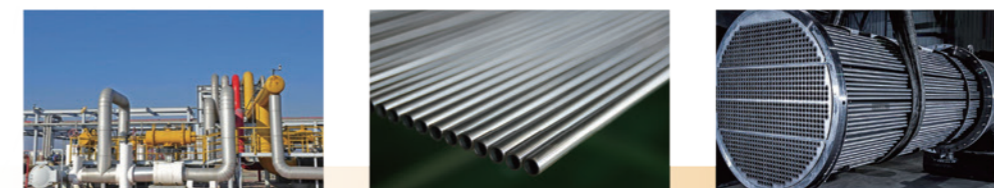

航空航天 & 核工程 & 能源领域

Aerospace & Nuclear Project & Energy

- **主要材质** Grade: TP321, TP316L, 合金 600 和合金 625
TP321, TP316L, Alloy600, Alloy625
- **钢管** Tubes and Pipes: AP & BA & EP
- **应用** Applications: 高温、耐腐蚀、抗氧化等特殊环境下的管道系统
Piping system in tough environments such as high temperature, corrosion resistance, oxidation resistance, etc



Outsourced Products

配套产品

TUBE & PIPE

管道

Tube
spec: ASTM A269/A270
material: 304/304L/316L
surface Finish: AP, BA, MP, EP

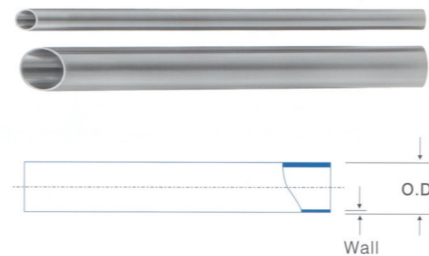

Size (规格)	O.D.(外径)	Wall (壁厚)		Type	Length (长度)
		SCH5S	SCH10S		mm
1/8"	3.18	0.56/0.71	-	Seamless	3000/6000
1/4"	6.35	0.89/1.00	1.65	Seamless	4000/6000
3/8"	9.53	0.89/1.00	1.65	Seamless	4000/6000
1/2"	12.70	1.00/1.24	2.11	Seamless	4000/6000
5/8"	15.88	1.24/1.65	2.11	Seamless	4000/6000
3/4"	19.05	1.24/1.65	2.11	Seamless	4000/6000
1"	25.40	1.65	2.77	Seamless/Welded	4000/6000
1.25"	31.75	1.65	2.77	Seamless/Welded	6000
1.5"	38.10	1.65	2.77	Seamless/Welded	6000
2"	50.80	1.65	2.77	Seamless/Welded	6000
2.5"	63.50	1.65	3.05	Seamless/Welded	6000
3"	76.20	1.65	3.05	Seamless/Welded	6000
4"	101.60	2.11	3.05	Seamless/Welded	6000
5"	127.00	2.11	3.40	Welded	6000
6"	152.40	2.77	3.40	Welded	6000
8"	203.20	2.77	3.76	Welded	6000
10"	254.00	3.40	4.19	Welded	6000
12"	304.80	3.96	4.57	Welded	6000

TUBE & PIPE

管道

Pipe
spec: JIS G3459
material: 304/304L/316L
surface Finish: AP, BA, MP, EP

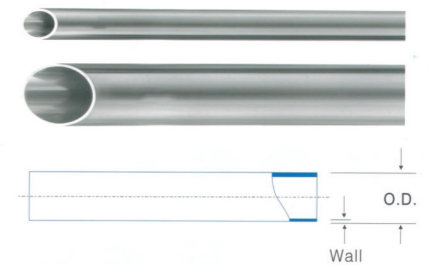

Size (规格)	O.D.(外径)	Wall (壁厚)		Type	Length (长度)
		SCH5S	SCH10S		mm
15A	21.7	1.65	2.10	Seamless	4000/6000
20A	27.2	1.65	2.10	Seamless/Welded	6000
25A	34.0	1.65	2.80	Seamless/Welded	6000
32A	42.7	1.65	2.80	Seamless/Welded	6000
40A	48.6	1.65	2.80	Seamless/Welded	6000
50A	60.5	1.65	2.80	Seamless/Welded	6000
65A	76.3	2.10	3.00	Seamless/Welded	6000
80A	89.1	2.10	3.00	Seamless/Welded	6000
100A	114.3	2.10	3.00	Seamless/Welded	6000
125A	139.8	2.80	3.40	Welded	6000
150A	165.2	2.80	3.40	Welded	6000
200A	216.3	2.80	4.00	Welded	6000
250A	267.4	3.40	4.00	Welded	6000
300A	318.5	4.00	4.50	Welded	6000
350A	355.6	4.00	5.00	Welded	6000
400A	406.4	4.50	5.00	Welded	6000
450A	457.2	4.50	5.00	Welded	6000
500A	508.0	5.00	5.50	Welded	6000
550A	558.8	5.00	5.50	Welded	6000
600A	609.6	5.50	6.50	Welded	6000
650A	660.4	5.50	8.00	Welded	6000
700A	711.2	5.50	8.00	Welded	6000
750A	762.0	6.50	8.00	Welded	6000
800A	812.8	-	8.00	Welded	6000

90° Elbow, Long (Pipe) 90° 弯头
JIS B2312/B2313



WELD FITTINGS

焊接配件

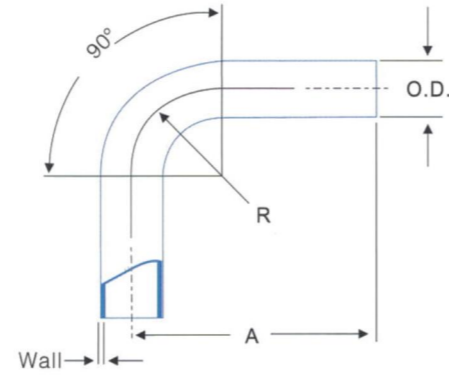

Size	O.D.	Wall	Wall	A	R
15A	21.7	1.65	2.1	75	38.1
20A	27.2	1.65	2.1	75	38.1
25A	34.0	1.65	2.8	75	38.1
32A	42.7	1.65	2.8	94	47.6
40A	48.6	1.65	2.8	104	57.2
50A	60.5	1.65	2.8	123	76.2
65A	76.3	2.10	3.0	147	95.3
80A	89.1	2.10	3.0	166	114.3
100A	114.3	2.10	3.0	204	152.4
125A	139.8	2.80	3.4	250	190.5
150A	165.2	2.80	3.4	290	228.6
200A	216.3	2.80	4.0	375	304.8
250A	267.4	3.40	4.0	461	381.0
300A	318.5	4.00	4.5	537	457.2
350A	355.6	4.00	5.0	613	533.4
400A	406.4	4.50	5.0	690	609.6
450A	457.2	4.50	5.0	766	685.8
500A	508.0	5.00	5.5	842	762.0
550A	558.8	5.00	5.5	911	838.2
600A	609.6	5.50	6.5	994	914.4
650A	660.4	5.50	8.0	995	915.4
700A	711.2	5.50	8.0	996	916.4
750A	762.0	6.50	8.0	997	917.4
800A	812.8	-	8.0	998	918.4

WELD FITTINGS

焊接配件

90° Elbow, Long (Tube) 90° 弯头
ASTM A269/A270

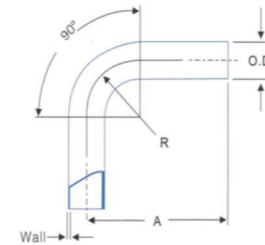

Size	O.D.	Wall	A	R
1/2"	12.70	1.24	76.2	28.6
5/8"	15.88	1.24	76.2	28.6
3/4"	19.05	1.65	76.2	28.6
1"	25.40	1.65	76.2	38.1
1.25"	31.75	1.65	95.3	57.2
1.5"	38.10	1.65	95.3	57.2
2"	50.80	1.65	120.7	76.2
2.5"	63.50	1.65	139.7	95.3
3"	88.90	1.65	158.8	114.3
4"	101.60	2.11	203.2	152.4
6"	152.40	2.77	292.1	228.6

45° Elbow, Long (Pipe) 45° 弯头
JIS B2312/B2313

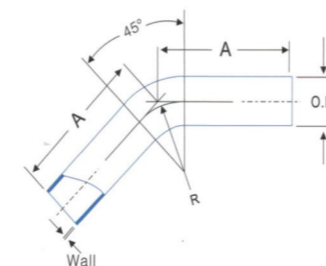

Size	O.D.	Wall	Wall	A	R
15A	21.7	1.65	2.8	52	38.1
20A	27.2	1.65	2.8	52	38.1
25A	34.0	1.65	2.8	52	38.1
32A	42.7	1.65	2.8	66	47.6
40A	48.6	1.65	3.0	70	57.2
50A	60.5	1.65	3.0	78	76.2
65A	76.3	2.10	3.0	91	95.3
80A	89.1	2.10	3.4	99	114.3
100A	114.3	2.10	3.4	115	152.4
125A	139.8	2.80	4.0	145	190.5
150A	165.2	2.80	4.0	155	228.6
200A	216.3	2.80	4.5	195	304.8
250A	267.4	3.40	5.0	237	381.0
300A	318.5	4.00	5.0	269	457.2
350A	355.6	4.00	5.0	296	533.4
400A	406.4	4.50	5.5	333	609.6
450A	457.2	4.50	5.5	365	685.8
500A	508.0	5.00	6.5	400	762.0
550A	558.8	5.00	8.0	432	838.2
600A	609.6	5.50	8.0	464	914.4
650A	660.4	5.50	8.0	995	915.4
700A	711.2	5.50	8.0	996	916.4
750A	762.0	6.50	8.0	997	917.4
800A	812.8	-	8.0	998	918.4

WELD FITTINGS

焊接配件

45° Elbow, Long (Tube) 45° 弯头
ASTM A269/A270

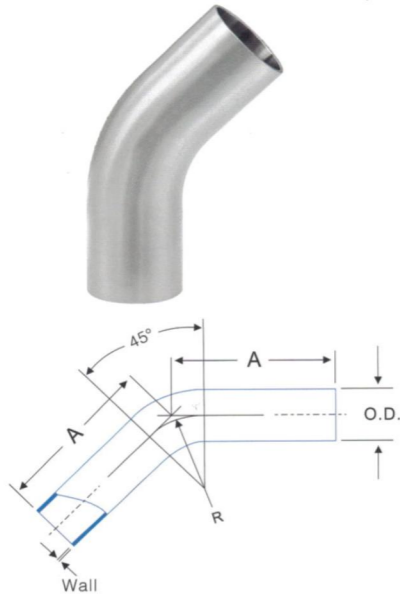

Size	O.D.	Wall	A	R
1/2"	12.70	1.24	57.2	28.6
5/8"	15.88	1.24	57.2	28.6
3/4"	19.05	1.65	57.2	28.6
1"	25.40	1.65	57.2	38.1
1.25"	31.75	1.65	63.5	57.2
1.5"	38.10	1.65	63.5	57.2
2"	50.80	1.65	76.2	76.2
2.5"	63.50	1.65	85.9	95.3
3"	88.90	1.65	92.0	114.3
4"	101.60	2.11	114.3	152.4
6"	152.40	2.77	158.9	228.6

90° Elbow, Short (Pipe) 90° 弯头
JIS B2312/B2313



Size	O.D.	Wall	Wall	A
15A	21.7	1.65	2.1	38.1
20A	27.2	1.65	2.1	38.1
25A	34.0	1.65	2.8	38.1
32A	42.7	1.65	2.8	47.6
40A	48.6	1.65	2.8	57.2
50A	60.5	1.65	2.8	76.2
65A	76.3	2.10	3.0	95.3
80A	89.1	2.10	3.0	114.3
100A	114.3	2.10	3.0	152.4
125A	139.8	2.80	3.4	190.5
150A	165.2	2.80	3.4	228.6
200A	216.3	2.80	4.0	304.8
250A	267.4	3.40	4.0	381.0
300A	318.5	4.00	4.5	457.2
350A	355.6	4.00	5.0	533.4
400A	406.4	4.50	5.0	609.6
450A	457.2	4.50	5.0	685.8
500A	508.0	5.00	5.5	762.0
550A	558.8	5.00	5.5	838.2
600A	609.6	5.50	6.5	914.4
650A	660.4	5.50	8.0	990.6
700A	711.2	5.50	8.0	1066.8
750A	762.0	6.50	8.0	1143.0
800A	812.8	-	8.0	1219.2

90° Elbow, Short (Tube) 90° 弯头
ASTM A269/A270



Size	O.D.	Wall	A
1/2"	12.70	1.24	19.1
5/8"	15.88	1.24	28.6
3/4"	19.05	1.65	28.6
1"	25.40	1.65	38.1
1.25"	31.75	1.65	57.2
1.5"	38.10	1.65	57.2
2"	50.80	1.65	76.2
2.5"	63.50	1.65	95.3
3"	88.90	1.65	114.3
4"	101.60	2.11	228.6

45° Elbow, Short (Pipe) 45° 弯头
JIS B2312/B2313



Size	O.D.	Wall	Wall	A
15A	21.7	1.65	2.1	15.8
20A	27.2	1.65	2.1	15.8
25A	34.0	1.65	2.8	15.8
32A	42.7	1.65	2.8	19.7
40A	48.6	1.65	2.8	23.7
50A	60.5	1.65	2.8	31.6
65A	76.3	2.10	3.0	39.5
80A	89.1	2.10	3.0	47.3
100A	114.3	2.10	3.0	63.1
125A	139.8	2.80	3.4	78.9
150A	165.2	2.80	3.4	94.7
200A	216.3	2.80	4.0	126.3
250A	267.4	3.40	4.0	157.8
300A	318.5	4.00	4.5	189.4
350A	355.6	4.00	5.0	220.9
400A	406.4	4.50	5.0	252.5
450A	457.2	4.50	5.0	284.1
500A	508.0	5.00	5.5	315.6
550A	558.8	5.00	5.5	347.2
600A	609.6	5.50	6.5	378.7
650A	660.4	5.50	8.0	410.3
700A	711.2	5.50	8.0	441.9
750A	762.0	6.50	8.0	473.4
800A	812.8	-	8.0	505.0

WELD FITTINGS

焊接配件

45° Elbow, Short (Tube) 45° 弯头
ASTM A269/A270

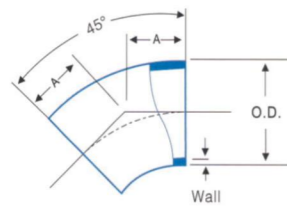

Size	O.D.	Wall	A
1/2"	12.70	1.24	19.4
5/8"	15.88	1.24	19.4
3/4"	19.05	1.65	19.4
1"	25.40	1.65	30.2
1.25"	31.75	1.65	41.3
1.5"	38.10	1.65	41.3
2"	50.80	1.65	58.7
2.5"	63.50	1.65	76.2
3"	88.90	1.65	93.7
4"	101.60	2.11	122.2

Equal Tee, Long (Pipe) 同径三通
JIS B2312/B2313

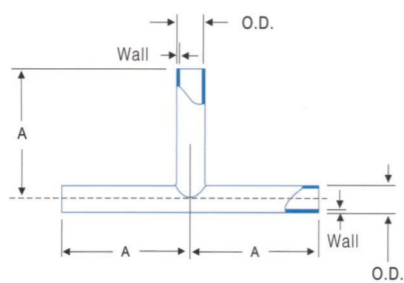
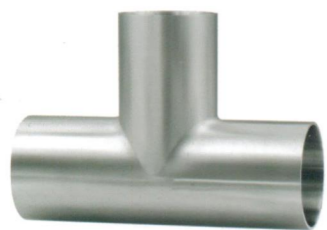

Size	O.D.	Wall	Wall	A
15A	21.7	1.65	2.1	25.4
20A	27.2	1.65	2.1	28.6
25A	34.0	1.65	2.8	38.1
32A	42.7	1.65	2.8	47.6
40A	48.6	1.65	2.8	57.2
50A	60.5	1.65	2.8	63.5
65A	76.3	2.10	3.0	76.2
80A	89.1	2.10	3.0	85.7
100A	114.3	2.10	3.0	104.8
125A	139.8	2.80	3.4	123.8
150A	165.2	2.80	3.4	142.9
200A	216.3	2.80	4.0	177.8
250A	267.4	3.40	4.0	215.9
300A	318.5	4.00	4.5	254.0
350A	355.6	4.00	5.0	279.4
400A	406.4	4.50	5.0	304.8
450A	457.2	4.50	5.0	342.9
500A	508.0	5.00	5.5	381.0
550A	558.8	5.00	5.5	419.1
600A	609.6	5.50	6.5	431.8
650A	660.4	5.50	8.0	495.3
700A	711.2	5.50	8.0	520.7
750A	762.0	6.50	8.0	558.8
800A	812.8	-	8.0	596.9

WELD FITTINGS

焊接配件

Equal Tee, Long (Tube) 同径三通
ASTM A269/A270

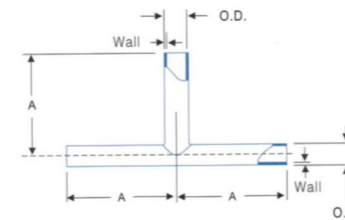

Size	O.D.	Wall	A
1/4"	6.35	0.89	44.5
3/8"	9.53	0.89	44.5
1/2"	12.70	1.24	47.6
5/8"	15.88	1.24	50.8
3/4"	19.05	1.65	50.8
1"	25.40	1.65	54
1.25"	31.75	1.65	60.3
1.5"	38.10	1.65	60.3
2"	50.80	1.65	73
2.5"	63.50	1.65	79.4
3"	88.90	1.65	85.7
4"	101.60	2.11	104.8
6"	152.40	2.77	142.9

Reducing Tee, Long (Tube) 异径三通
ASTM A269/A270

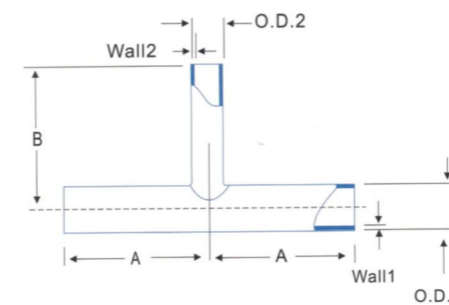

O.D.1	O.D.2	A	B
3/8"	1/4"	44.5	44.5
1/2"	3/8", 1/4"	47.6	47.6
5/8"	1/2", 3/8", 1/4"	50.8	50.8
3/4"	5/8", 1/2", 3/8", 1/4"	50.8	50.8
1"	3/4", 5/8", 1/2", 3/8", 1/4", 15A	54	54
1.25"	1", 3/4", 5/8", 1/2", 3/8", 1/4", 20A, 15A	60.3	60.3
1.5"	1.25", 1", 3/4", 5/8", 1/2", 3/8", 1/4" 25A, 20A, 15A	60.3	60.3
2"	1.5", 1.25", 1", 3/4", 5/8", 1/2", 3/8", 1/4" 40A, 32A, 25A, 20A, 15A	73	73
2.5"	2", 1.5", 1.25", 1", 3/4", 5/8", 1/2", 3/8", 1/4" 50A, 40A, 32A, 25A, 20A, 15A	79.4	79.4
3"	2.5", 2", 1.5", 1.25", 1", 3/4", 5/8", 1/2", 3/8", 1/4" 50A, 40A, 32A, 25A, 20A, 15A	85.7	85.7
4"	3", 2.5", 2", 1.5", 1.25", 1", 3/4", 5/8", 1/2", 3/8", 1/4" 80A, 65A, 50A, 40A, 32A, 25A, 20A, 15A	104.8	104.8
5"	4", 3", 2.5", 2", 1.5", 1.25", 1" 3/4", 5/8", 1/2", 3/8", 1/4" 100A, 80A, 65A, 50A, 40A, 32A, 25A, 20A, 15A	142.9	142.9
6"	5", 4", 3", 2.5", 2", 1.5", 1.25", 1" 3/4", 5/8", 1/2", 3/8", 1/4" 125A, 100A, 80A, 65A, 50A, 40A, 32A, 25A, 20A, 15A	142.9	142.9

WELD FITTINGS

焊接配件

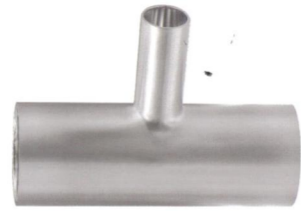

Reducing Tee, Long (Pipe) 异径三通
JIS B2312/B2313

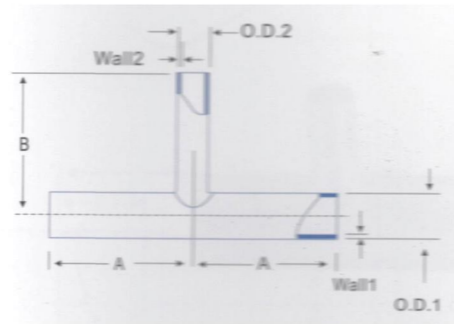

O.D.1	O.D.2	A	B
15A	1/2", 3/8", 1/4"	47	44
	3/4", 5/8"	52	52
20A	1/2", 3/8", 1/4"	47	47
	15A, 1", 3/4", 5/8"	55	55
25A	1/2", 3/8", 1/4"	47	50
	20A, 15A, 1.25", 1", 3/4", 5/8"	59	59
32A	1/2", 3/8", 1/4"	57	54
	3/4", 5/8"	68	62
	25A, 20A, 15A, 1.25", 1"		
40A	1/2", 3/8", 1/4"	57	57
	25A, 20A, 15A, 1", 3/4", 5/8"	68	65
	32A, 1.5", 1.25"	77	77
50A	1/2", 3/8", 1/4"	57	63
	25A, 20A, 15A, 1", 3/4", 5/8"	68	71
	40A, 32A, 2", 1.5", 1.25"	83	83
65A	1/2", 3/8", 1/4"	61	71
	25A, 20A, 15A, 1", 3/4", 5/8"	72	79
	50A, 40A, 32A, 2", 1.5", 1.25"	88	90
	2.5"	97	97
80A	1/2", 3/8", 1/4"	61	77
	25A, 20A, 15A, 1", 3/4", 5/8"	72	85
	50A, 40A, 32A, 2", 1.5", 1.25"	88	96
	65A, 3", 2.5"	103	103
100A	1/2", 3/8", 1/4"	61	90
	25A, 20A, 15A, 1", 3/4", 5/8"	72	98
	50A, 40A, 32A, 2", 1.5", 1.25"	88	109
	80A, 65A, 4", 3", 2.5"	116	116

WELD FITTINGS

焊接配件



Reducing Tee, Short (Pipe) 异径三通
JIS B2312/B2313

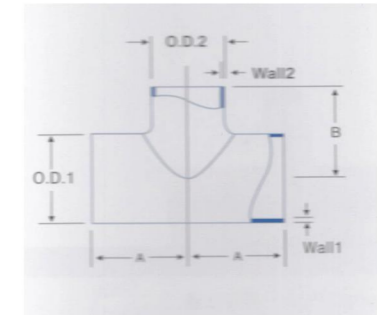

O.D.1	O.D.2	A	B
125A	1/2", 3/8", 1/4"	80	110
	25A, 20A, 15A, 1", 3/4", 5/8"	100	120
	50A, 40A, 32A, 2", 1.5", 1.25"	120	130
	100A, 80A, 65A, 4", 3", 2.5"	140	140
150A	5"	160	160
	1/2", 3/8", 1/4"	90	130
	25A, 20A, 15A, 1", 3/4", 5/8"	110	140
	50A, 40A, 32A, 2", 1.5", 1.25"	1.30	150
200A	100A, 80A, 65A, 4", 3", 2.5"	1.50	160
	125A, 5"	170	170
	1/2", 3/8", 1/4"	100	150
	25A, 20A, 15A, 1", 3/4", 5/8"	120	160
250A	50A, 40A, 32A, 2", 1.5", 1.25"	140	170
	100A, 80A, 65A, 4", 3", 2.5"	160	180
	150A, 125A, 6", 5"	180	190
	1/2", 3/8", 1/4"	110	180
300A	25A, 20A, 15A, 1", 3/4", 5/8"	130	190
	50A, 40A, 32A, 2", 1.5", 1.25"	1.50	200
	100A, 80A, 65A, 4", 3", 2.5"	170	210
	150A, 125A, 6", 5"	190	220
300A	200A	210	240
	1/2", 3/8", 1/4"	120	200
	25A, 20A, 15A, 1", 3/4", 5/8"	140	210
	50A, 40A, 32A, 2", 1.5", 1.25"	160	220
300A	100A, 80A, 65A, 4", 3", 2.5"	180	230
	150A, 125A, 6", 5"	200	240
	250A, 200A	220	260
	250A, 200A	220	260

WELD FITTINGS

焊接配件

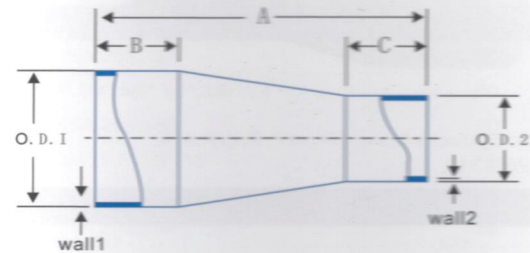

Concentric Reducer, Long (Tube) 同心大小头
ASTM A269/A270

O.D.1	O.D.2	A
3/4"	1/2"	101.6
1"	1/2"	114.3
	3/4", 5/8", 15A	101.6
1.25"	1/2"	139.7
	1", 3/4", 5/8", 20A, 15A	127.0
1.5"	1/2"	139.7
	1.25", 1", 3/4", 5/8", 25A, 20A, 15A	127.0
2"	1/2"	196.9
	1", 3/4", 5/8", 20A, 15A	184.2
2.5"	1.5", 1.25", 40A, 32A, 25A	133.4
	1/2"	247.7
3"	1", 3/4", 5/8", 20A, 15A	235.0
	1.5", 1.25", 40A, 32A, 25A	184.2
4"	2", 50A	139.7
	1/2"	298.5
3"	1", 3/4", 5/8", 20A, 15A	285.8
	1.5", 1.25", 40A, 32A, 25A	235.0
4"	2", 50A	190.5
	2.5"	139.7
3"	1/2"	406.4
	1", 3/4", 5/8", 20A, 15A	393.7
4"	1.5", 1.25", 40A, 32A, 25A	342.9
	2", 50A	298.5
3"	2.5"	247.7
	3", 80A, 65A	196.9

WELD FITTINGS

焊接配件

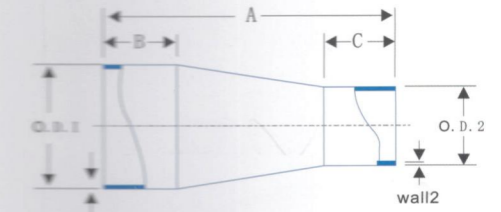

Concentric Reducer, Long (Pipe) 同心大小头
JIS B2312/B2313

O.D.1	O.D.2	A
15A	3/4", 5/8", 1/2"	100
20A	15A, 1", 3/4", 5/8", 1/2"	105
25A	20A, 15A, 1.25", 1", 3/4", 5/8", 1/2"	120
32A	25A, 20A, 15A, 1.5", 1.25", 1", 3/4", 5/8", 1/2"	125
40A	32A, 25A, 20A, 15A, 1.5", 1.25", 1", 3/4", 5/8"	130
50A	40A, 32A, 25A, 20A, 15A, 2", 1.5", 1.25", 1", 3/4"	140
65A	50A, 40A, 32A, 25A, 20A, 15A	165
	2.5", 2", 1.5", 1.25", 1", 3/4"	
80A	65A, 50A, 40A, 32A, 25A, 20A, 15A	170
	3", 2.5", 2", 1.5", 1.25", 1"	
100A	80A, 65A, 50A, 40A, 32A, 25A, 20A, 15A	180
	4", 3", 2.5", 2", 1.5", 1.25", 1"	
125A	100A, 80A, 65A, 50A, 40A, 32A, 25A, 20A	250
	4", 3", 2.5", 2", 1.5", 1.25", 1"	
150A	125A, 100A, 80A, 65A, 50A, 40A, 32A, 25A, 20A	260
	5", 4", 3", 2.5", 2", 1.5", 1.25", 1"	
200A	150A, 125A, 100A, 80A, 65A, 50A, 40A, 32A, 25A	280
	6", 5", 4", 3", 2.5", 2", 1.5", 1.25", 1"	
250A	200A, 150A, 125A	300
	100A, 80A, 65A, 50A, 40A, 32A, 25A	
300A	6", 5", 4", 3", 2.5", 2", 1.5", 1.25", 1"	325
	300A, 250A, 200A, 150A, 125A	
350A	100A, 80A, 65A, 50A, 40A, 32A, 25A	455
	6", 5", 4", 3", 2.5", 2", 1.5", 1.25", 1"	
400A	350A, 300A, 250A, 200A, 150A, 125A	480
	100A, 80A, 65A, 50A, 40A, 32A, 25A	
	6", 5", 4", 3", 2.5", 2", 1.5", 1.25", 1"	

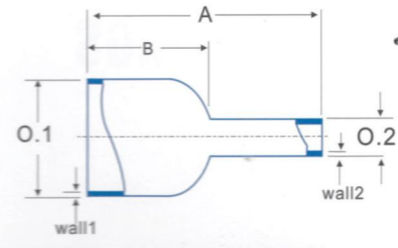

Cap Reducer 管帽大小头
ASTM A269/A270

O.D.1	O.D.2	A
32A	25A,20A,15A	80
	1.5",1.25",1",3/4",5/8",1/2",3/8",1/4"	80
40A/2"	25A,20A,15A	80
	1.25",1",3/4",5/8",1/2",3/8",1/4"	80
50A/2.5"	32A,1.5"	90
	25A,20A,15A	80
	1.25",1",3/4",5/8",1/2",3/8",1/4"	80
65A/3"	40A,32A,2",1.5"	90
	25A,20A,15A	80
	1.25",1",3/4",5/8",1/2",3/8",1/4"	80
80A	50A,40A,32A,2.5",2",1.5"	90
	25A,20A,15A	80
	1.25",1",3/4",5/8",1/2",3/8",1/4"	80
100A/4"	50A,40A,32A,2.5",2",1.5"	102
	65A,3"	110
	25A,20A,15A	105
	1.25",1",3/4",5/8",1/2",3/8",1/4"	105
125A	50A,40A,32A,2.5",2",1.5"	115
	80A,65A,3"	125
	25A,20A,15A	130
	1.25",1",3/4",5/8",1/2",3/8",1/4"	130
200A	50A,40A,32A,2.5",2",1.5"	140
	100A,80A,65A,4",3"	150
	25A,20A,15A	140
	1.25",1",3/4",5/8",1/2",3/8",1/4"	140
250A	50A,40A,32A,2.5",2",1.5"	150
	100A,80A,65A,4",3"	160
	125A	170
	25A,20A,15A	150
300A	1.25",1",3/4",5/8",1/2",3/8",1/4"	150
	50A,40A,32A,2.5",2",1.5"	160
	100A,80A,65A,4",3"	170
	200A,125A	180
300A	25A,20A,15A	190
	1.25",1",3/4",5/8",1/2",3/8",1/4"	190
	50A,40A,32A,2.5",2",1.5"	200
	100A,80A,65A,4",3"	200
300A	250A,200A,125A	210

WELD FITTINGS

焊接配件

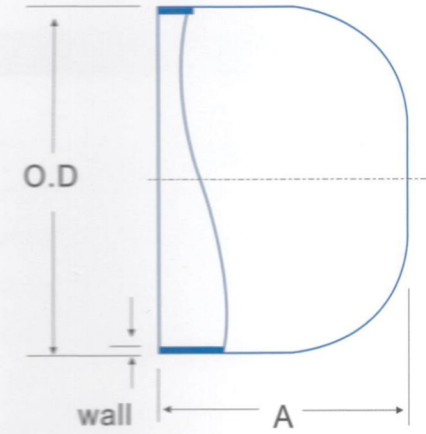

End Cap 管帽
ASTM A269/A270

O.D	A
20A,15A	25.4
1.25",1",3/4",5/8",1/2",3/8",1/4"	
65A,50A,40A,32A,25A	38.1
3",2.5",2",1.5"	
80A	50.8
100A,4"	63.5
125A	76.2
150A	88.9
200A	101.6
6"	121.6
250A	127
300A	152.4

Double Set Elbow 双套弯头
ASTM A269/A270

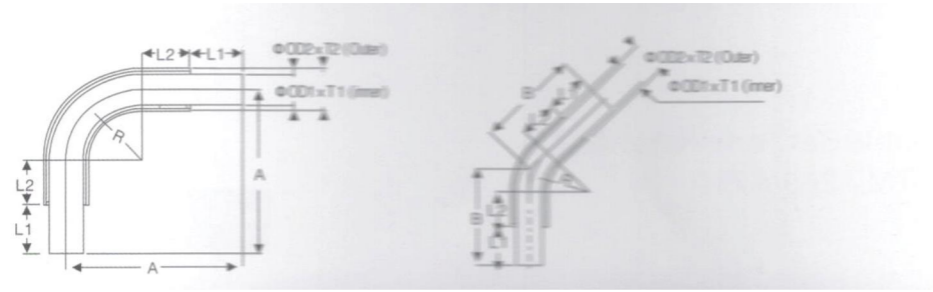

Inner tube	Outer tube	L1	L2	R	A	B
1/4"x0.89	1/2"x1.24	40	29	25	94	80
3/8"x0.89	5/8"x1.24	40	36	28	104	88
1/2"x1.24	3/4" x1.65	40	36	35	111	91
	15Ax1.65			38	114	92
3/4" x1.65	1"x1.65	40	36	47.6	124	96
	20Ax1.65					
1"x1.65	1.25"x1.65	40	36	57.2	134	100
	25Ax1.65					
1.25"x1.65	1.5"x1.65	40	36	76.2	150	110
1.5"x1.65	2"x1.65	46	46	95.3	188	132
2" x1.65	2.5"x1.65	46	51	120	217	147
15Ax1.65	25Ax1.65	40	36	57.2	134	100
20Ax1.65	32Ax1.65	40	46	76.2	163	118
25Ax1.65	40Ax1.65	40	46	95.3	182	126
32Ax1.65	50Ax1.65	40	46	114.3	207	140

DOUBLE SET OF FITTINGS

双套配件

Double Set Tee 双套三通
ASTM A269/A270

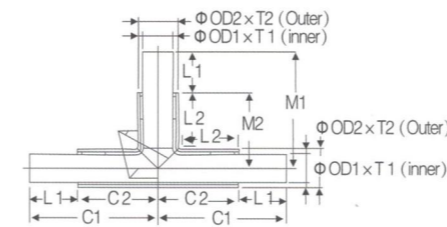

Inner tube	Outer tube	L1	L2	C1, M1	C2, M2
1/4"x0.89	1/2"x1.24	40	29	82	42
3/8"x0.89	5/8"x1.24	40	36	89	49
1/2" x1.24	3/4"x1.65	40	36	92	52
	15Ax1.65				
3/4"x1.65	1" x 1.65	40	36	95	55
	20Ax1.65				
1"x1.65	1.25"x1.65	40	36	99	59
	25Ax1.65				
1.25"x1.65	1.5"x1.65	40	36	108	65
1.5"x1.65	2"x1.65	46	46	123	77
2"x1.65	2.5"x1.65	46	51	136	90
15Ax1.65	25Ax1.65	40	36	99	59
20Ax1.65	32Ax1.65	40	46	114	74
25Ax1.65	40Ax1.65	40	46	117	77
32Ax1.65	50Ax1.65	40	46	129	83

Double Set Terminator 收尾环
ASTM A269/A270

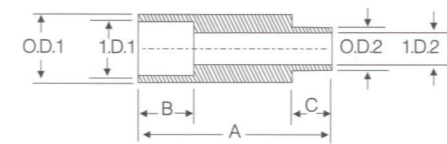

Inner tube	Outer tube	O.D.1	I.D.1	O.D.2	I.D.2	A	B	C
1/4"	1/2"	12.7	10.21	8.23	6.48	31.75	9.4	6.35
3/8"	5/8"	15.88	13.39	11.43	9.65	31.75	9.4	6.35
1/2"	3/4"	19.05	15.75	15.32	12.85	31.75	9.4	6.35
3/4"	1"	25.4	22.1	22.48	19.2	50.8	12.7	6.35
1"	1.25"	31.75	28.45	28.83	25.55	50.8	12.7	6.35
1.5"	2"	50.8	47.5	41.53	38.38	57.15	19.05	6.35
2"	2.5"	63.5	59.69	54.23	51.08	57.15	19.05	6.35

Double Set Sleeve 滑套
ASTM A269/A270

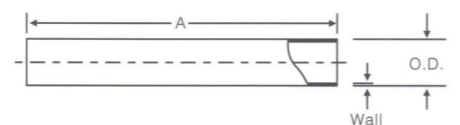

Inner tube	Outer tube	O.D.	Wall	A
1/4"	1/2"	15.88	1.5	101.6
3/8"	5/8"	19.05	1.5	101.6
1/2"	3/4"	22	1.37	101.6
3/4"	1"	28.6	1.5	101.6
1"	1.25"	35	1.5	101.6
1.5"	2"	54	1.5	114.3
2"	2.5"	66.8	1.5	114.3

CAST FITTINGS

铸造配件

90° Elbow 弯头

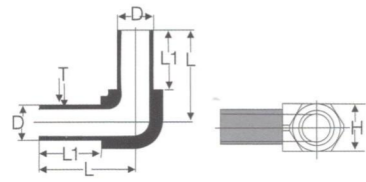

Size1	D	T	L	L1	H
1/4"	6.35	0.89/1	31.25	22	12.7
3/8"	9.53	0.89/1	31.25	22	12.7
1/2"	12.7	1/1.24	34	22	17.5
3/4"	19.05	1.24/1.65	33.5	22	22.8

Equal Tee 同径三通

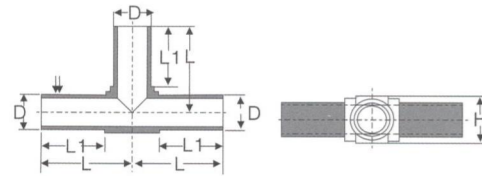

Size1	D	T	L	L1	H
1/4"	6.35	0.89/1.0	29	22	12.8
3/8"	9.53	0.89/1.0	29	22	12.8
1/2"	12.7	1.0/1.24	31.25	22	17.1
3/4"	19.05	1.24/1.65	34	22	23.2

Reducing Tee 异径三通

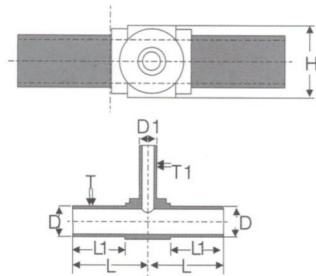

Size1	Size2	D	D1	T	T1	L	L1	H
3/8"	1/4"	9.53	6.35	0.89/1.0	0.89/1.0	29	22	12.8
1/2"	1/4"	12.7	6.35	0.89/1.0	0.89/1.0	31.25	22	17.1
1/2"	3/8"	12.7	9.53	1.0/1.24	0.89/1.0	31.25	22	17.1
3/4"	1/4"	19.05	6.35	1.24/1.65	0.89/1.0	34	22	23.2
3/4"	3/8"	19.05	9.53	1.24/1.65	0.89/1.0	34	22	23.2
3/4"	1/2"	19.05	12.7	1.24/1.65	1.0/1.24	34	22	23.2

同心大小头 Concentric Reducer

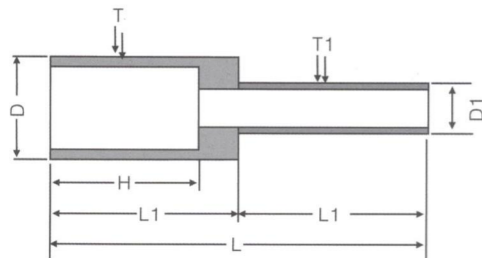

Size1	Size2	D	D1	T	T1	L	L1	H
3/8"	1/4"	9.53	6.35	0.89/1.0	0.89/1.0	44	22	17.5
1/2"	1/4"	12.7	6.35	1.0/1.24	0.89/1.0	44	22	17.5
1/2"	3/8"	12.7	9.53	1.0/1.24	0.89/1.0	44	22	17.5
3/4"	1/4"	19.05	6.35	1.24/1.65	0.89/1.0	44	22	17.5
3/4"	3/8"	19.05	9.53	1.24/1.65	0.89/1.0	44	22	17.5
3/4"	1/2"	19.05	12.7	1.24/1.65	1.0/1.24	44	22	17.5
1"	1/4"	25.4	6.35	1.65	0.89/1.0	44	22	17.5
1"	3/8"	25.4	9.53	1.65	0.89/1.0	44	22	17.5
1"	1/2"	25.4	12.7	1.65	1.0/1.24	44	22	17.5
1"	3/4"	25.4	19.05	1.65	1.24/1.65	44	22	17.5

VCR FITTINGS

面密封配件

VCR 接头安装指南

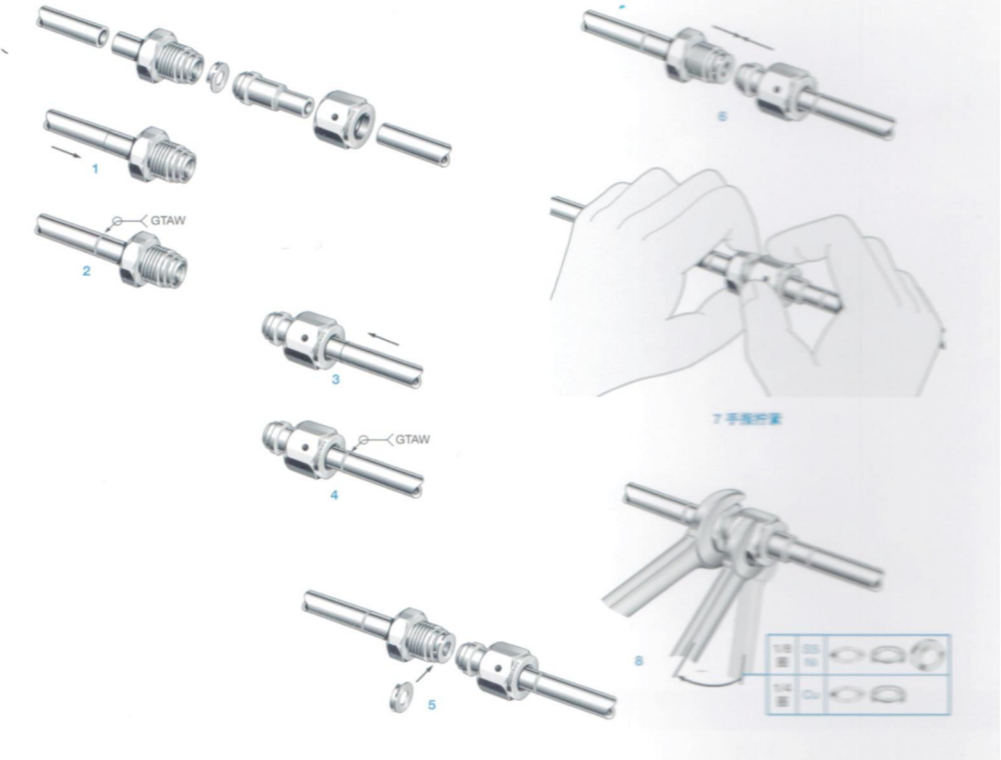

Short Gland 接头

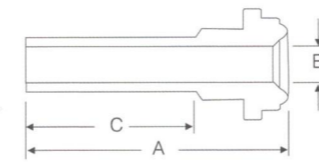

Tube Size	VCR Size	A	C	E
1/4"	1/4"	27.9	19.1	6.4
1/4"	1/2"	28.4	19.1	6.4
3/8"	1/2"	28.4	19.1	7.9
1/2"	1/2"	28.4	19.1	10.2
3/4"	3/4"	34.5	19.1	16.5
1"	1"	38.6	19.1	22.1

Long Gland 接头



Tube Size	VCR Size	A	C	E
1/4"	1/4"	43.2	19.1	6.4
1/4"	1/2"	45.5	19.1	6.4
3/8"	1/2"	45.5	19.1	7.9
1/2"	1/2"	45.5	19.1	10.2
3/4"	3/4"	51.6	19.1	16.5
1"	1"	58.9	19.1	22.1

HVCR Gland 接头

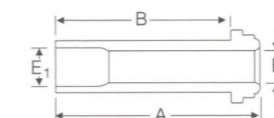

Tube Size	VCR Size	A	C	E	E1
3/8"	1/4"	33.3	28.4	6.4	7.9

VCR FITTINGS

面密封配件

Nut Female 内螺纹螺母

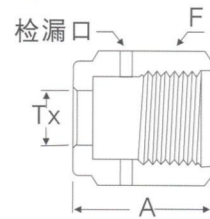

VCR Size	A	F	Tx
1/4"	20.5	19.1	9.1
3/8"	22.3	27.0	15.5
1/2"	22.3	27.0	15.5
3/4"	28.4	38.1	22.6
1"	34.0	44.5	30.5
1/4"(HVCR)	20.6	19.1	9.9

Nut Male 外螺纹螺母

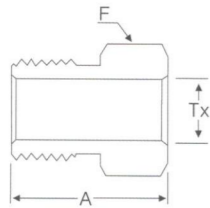

VCR Size	A	F	Tx
1/4"	18.0	15.9	9.1
3/8"	20.5	23.8	15.5
1/2"	20.5	23.8	15.5
3/4"	25.4	33.3	22.6
1"	30.2	41.3	30.5
1/4"(HVCR)	18.0	19.1	9.9

CAP 堵帽

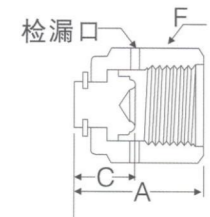

VCR Size	A	F	Tx
1/4"	24.2	11.2	19.1
3/8"	25.5	11.4	27.0
1/2"	25.5	11.4	27.0
3/4"	32.8	13.7	38.1
1"	39.1	16.0	44.5

Gasket 垫片

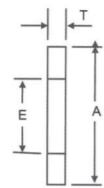

VCR Size	A	F	Tx
1/4"	11.9	5.6	0.8
3/8"	19.8	11.2	0.8
1/2"	19.8	11.2	0.8
3/4"	29.0	16.8	0.8
1"	35.6	22.6	0.8

Gasket 带爪垫片



VCR Size	A	F	Tx
1/4"	12.7	6.1	0.8
3/8"	20.1	11.2	0.8
1/2"	20.1	11.2	0.8
3/4"	29.0	16.8	0.8
1"	35.6	22.6	0.8

LOK FITTINGS

卡套配件

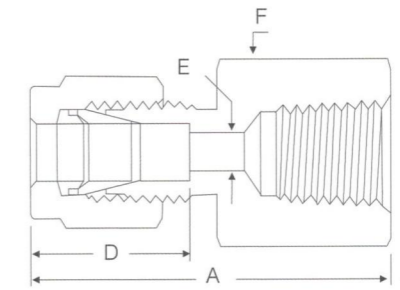

FNPT Union 卡套转内螺纹接头

Tube Size	NPT Size	A	D	E	F
1/8"	1/8"	28.7	12.7	2.0	14.0
1/8"	1/4"	33.5	12.7	2.0	17.0
1/4"	1/8"	31.2	15.3	5.0	14.0
1/4"	1/4"	35.8	15.3	5.0	17.0
1/4"	3/8"	37.6	15.3	5.0	22.0
1/4"	1/2"	42.4	15.3	5.0	27.0
3/8"	1/8"	32.8	16.8	5.0	17.0
3/8"	1/4"	37.6	16.8	6.0	17.0
3/8"	3/8"	39.1	16.8	8.0	22.0
3/8"	1/2"	43.9	16.8	8.0	27.0
3/8"	3/4"	47.8	16.8	8.0	32.0
1/2"	1/8"	37.3	22.8	5.0	22.0
1/2"	1/4"	40.4	22.8	6.0	22.0
1/2"	3/8"	42.0	22.8	8.0	22.0
1/2"	1/2"	46.7	22.8	10.0	27.0
1/2"	3/4"	48.3	22.8	10.0	32.0
1/2"	1"	51.3	22.8	10.0	40.0
5/8"	3/8"	42.1	24.4	8.0	27.0
5/8"	1/2"	46.9	24.4	11.0	27.0
5/8"	3/4"	48.5	24.4	12.0	32.0
3/4"	1/2"	46.7	24.4	15.0	27.0
3/4"	3/4"	48.3	24.4	15.0	32.0
1"	3/4"	53.3	31.3	21.0	35.0
1"	1"	62.2	31.3	21.0	40.0

BALL VALVE SERIES

球阀系列

卡套式球阀 SWG Valve (Compression)

Size	Orifice	A	B	C	D	E	F	G
1/4"	4.8	67.7	10.5	10.5	38.0	6.0	33.0	14.5
3/8"	7.1	75.1	12.5	12.5	40.7	6.0	41.0	16.5
1/2"	10.0	80.3	15.5	15.5	42.9	6.0	50.5	16.5
3/4"	10.0	83.0	15.5	15.5	42.9	6.0	50.5	16.5

Working temperature: -28°C to 232°C
Up to 1000psig (68.9bar)
Panel mountable

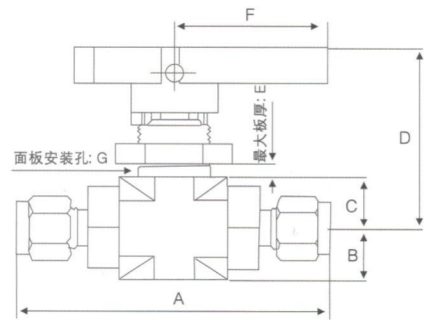

Part description	Material
Body	SUS316
Cap	SUS316L
Ball	SUS316
Stem	SUS316
Seat	PTFE
Panel Nut	SUS316
Packing	PTFE
Handle	Nylon

Size	Orifice	A	B	W	一字手柄	尼龙手柄	Y
1/4"	4.8	76.2	41.7	17.5	65.0	20.0	31.5
3/8"	7.1	78.2	44.2	20.6	85.0	25.0	37.3
1/2"	9.0	90.2	51.1	27.0	85.0	25.0	40.5
3/4"	12.0	96.2	54.1	30.0	110.0	-	52.0
1"	15.0	113.8	64.5	36.0	110.0	-	55.0

Working temperature: -28°C to 80°C
Up to 1000psig (68.9bar)

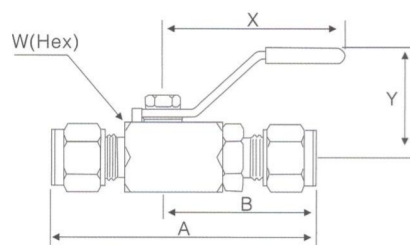

Part description	Material
Body	SUS316
Cap	SUS316L
Ball	SUS316
Stem	SUS316
Seat	PTFE
Packing	PTFE
Handle	Nylon/SUS304

STAINLESS STEEL THREE PICECE BALL VALVE

不锈钢三片式球阀

MOXANPURE球阀经过100%压力测试、清洗，并在1000级洁净室中组装。

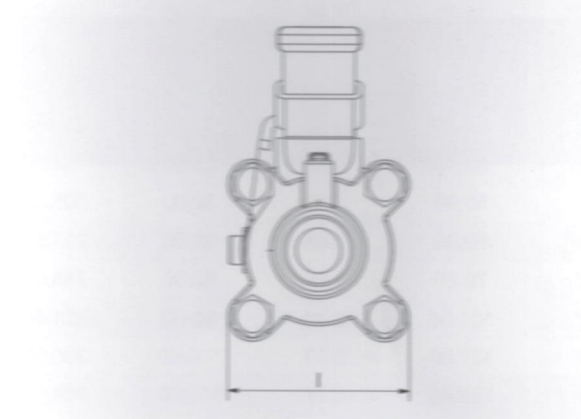
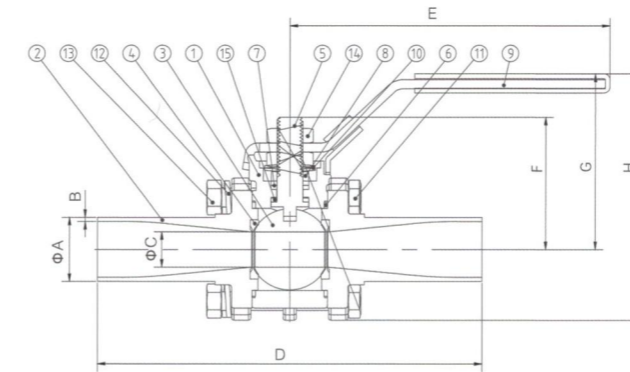

序号	部件	描述
1	300不锈钢系列	本体
2	304/316L	端部连接
3	300不锈钢系列	球
4	PTFE	球密封
5	300不锈钢系列	阀杆
6	PTFE	车身密封
7	PTFE	阀杆密封
8	300不锈钢系列	密封压盖
9	300不锈钢系列, 乙烯基	使提手式模块
10	300不锈钢系列	盘式弹簧
11	300不锈钢系列	螺栓
12	300不锈钢系列	弹簧垫圈
13	300不锈钢系列	螺母
14	300不锈钢系列	阀杆螺母
15	PTFE	阀杆填料

STAINLESS STEEL THREE PICECE BALL VALVE

不锈钢三片式球阀

技术参数 technical parameter

尺寸	A	B	C	D	E	F	G	H	I
15A	21.70	1.65	10.00	135.00	136.00	38.70	71.00	95.80	49.50
20A	27.20	1.65	15.00	162.30	162.00	56.00	76.30	106.60	60.60
25A	34.00	1.65	20.60	163.40	162.00	56.00	76.30	106.60	60.60
32A	42.70	1.65	25.00	194.00	162.00	60.60	80.30	113.60	66.60
40A	48.60	1.65	32.00	205.20	202.00	76.30	92.00	132.00	79.60
50A	60.50	1.65	40.00	211.50	202.00	86.50	98.60	142.00	86.70
65A	76.30	2.10	50.00	248.00	202.00	99.50	111.20	164.00	105.70
80A	89.10	2.10	65.00	262.00	330.00	134.50	153.50	224.70	160.90
100A	114.30	2.10	80.00	301.00	330.00	145.50	165.50	252.50	196.00
125A	139.80	2.80	100.00	330.00	500.00	172.00	187.30	288.50	229.00
150A	165.20	2.80	125.00	364.00	500.00	192.00	207.50	333.00	250.80
1/2"	12.70	1.24	10.00	103.00	129.00	34.30	50.00	71.00	42.20
3/4"	19.05	1.24/1.65	10.00	135.00	136.00	38.70	71.00	95.80	49.50
1"	25.40	1.24/1.65	15.00	162.30	162.00	56.00	76.30	106.60	60.60
1.25"	31.75	1.65	20.60	163.40	162.00	56.00	76.30	106.60	60.60
1.5"	38.10	1.65	25.00	194.00	162.00	60.60	80.30	113.60	66.60
2"	50.80	1.65	32.00	205.20	202.00	76.30	92.00	132.00	79.60
2.5"	63.50	1.65	40.00	211.50	202.00	86.50	98.60	142.00	86.70
3"	76.20	1.65	50.00	248.00	202.00	99.50	111.20	164.00	105.70
4"	101.60	2.10	80.00	301.00	330.00	145.50	165.50	252.50	196.00
5"	127.00	2.77	100.00	330.00	500.00	172.00	187.30	288.50	229.00
6"	152.40	2.77	125.00	364.00	500.00	192.00	207.50	333.00	250.80

管道 (A26)	球孔	Cv值
1/2"	10	17
3/4"	10	17
1"	15	37
1.25"	20	68
1.5"	25	110
2"	32	186
2.5"	38	269
3"	50	481
4"	80	1,301
5"	100	2,085
6"	125	3,338
8"	150	4,902

日标管尺寸	球孔	Cv值
15A	10	17
20A	15	37
25A	20.6	68
32A	25	110
40A	32	186
50A	40	269
65A	50	481
80A	65	839
100A	80	1,301
125A	100	2,085
150A	125	3,338
200A	180	4,902
250A	220	10,765
300A	260	16,811

FLANGES

法兰

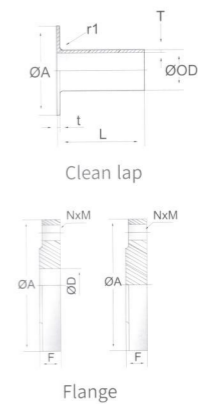
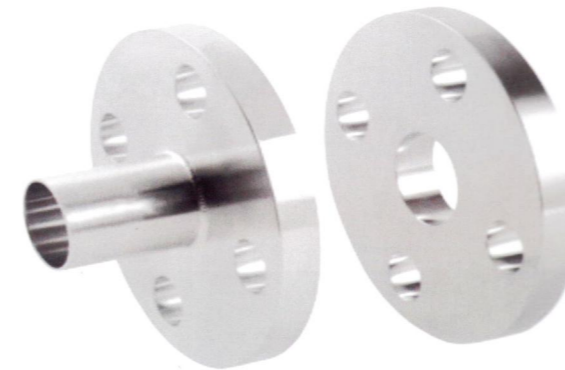

Size	Pipe flange	Flange,Blind				Teflon packing	
	Length	Outside dia.	Thick-ness	No.of bolts	Dia.of bolt	Outside dia.	Inside dia.
OD	L	A	F	N	M	OD	ID
15A	100	95	12	4	M12	58	50
20A	100	100	14	4	M12	63	55
25A	100	125	14	4	M12	74	65
32A	100	135	16	4	M16	84	78
40A	100	140	16	4	M16	89	83
50A	100	155	16	4	M16	104	93
65A	100	175	18	4	M16	124	118
80A	100	185	18	8	M16	134	129
100A	100	210	18	8	M16	159	149
125A	150	250	20	8	M20	190	184
150A	150	280	22	8	M20	220	214
200A	150	330	22	12	M20	270	260

Size	Tube flange	Flange,Blind				Teflon packing	
	Length	Outside dia.	Thick-ness	No.of bolts	Dia.of bolt	Outside dia.	Inside dia.
OD	L	A	F	N	M	OD	ID
3/4"	100	95	12	4	M12	58	19.5
1"	100	100	14	4	M12	63	26
1.25"	100	125	14	4	M16	74	32.5
1.5"	100	135	16	4	M16	84	38.5
2"	100	140	16	4	M16	89	51.5
2.5"	100	155	16	4	M16	104	64
3"	100	175	18	4	M16	124	77
4"	100	195	18	8	M16	144	102.5
5"	150	250	20	8	M20	190	128
6"	150	280	22	8	M20	220	153.5

Qualification Certificate

资质证书

- 2022年(BOTONG)获得AD2000 W0质量认证
2022 (BOTONG) AD2000 W0 quality certification
- 2022年(BOTONG)获得ISO9001:2015认证
ISO9001:2015 approved in 2022
- 2022年(BOTONG)获得欧盟承压委员会颁发的Pressure Equipment Directive证书
Pressure Equipment Directive approved in 2022
- 2022年(BOTONG)获得特种设备生产认证
TS certificate approved in 2022
- 2024年(BOTONG)获得镍基合金型式试验证书
Type Test Certificate for Nickel - based Alloys certificate approved in 2024
- 2024年(BOTONG)获得武器装备质量管理体系认证证书
Certificate of Military Standard certificate approved in 2024
- 2024年(BOTONG)获得浙江制造认证
Zhejiang Manufacturing certificate approved in 2024
- 2023年(BOTONG)获得ISO45001认证
ISO45001 approved in 2023
- 2023年(BOTONG)获得ISO14001认证
ISO14001 approved in 2023



Honors

资质荣誉

Certificate of Honor















荣誉证书

- 2022年(BOTONG)成为上海实验室装备协会支持单位
Became the support unit of SLEA in 2022
- 2022年(BOTONG)获得上海钢管协会团体会员证书
Obtained a group membership certificate of SSTA in 2022
- 2022年(BOTONG)成为2022年第一批浙江省科技型中小企业
Became the first batch of Zhejiang Province SMES in 2022
- 2022年获得湖州市级科技企业研发中心
Huzhou Municipal science and technology Enterprise R&D Center in 2022
- 2023年获得浙江省创新型中小企业
Specialized Innovative Small and Medium-sized Enterprise of Zhejiang in 2023
- 2024年获得浙江省专精特新中小企业
Specialized High-tech Small and Medium-sized Enterprise of Zhejiang in 2024

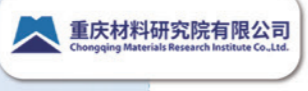

Company's Achievements

公司部分业绩

北方华创科技集团股份有限公司		316L不锈钢精密管道、球阀	中国轻工建设工程有限公司		316L/304L BA 管道 316L/304L AP 管道 316L/304L 阀门、管件
华海清科股份有限公司		316L不锈钢精密管道、球阀、管件	中国电子系统工程第三建设有限公司		316L 不锈钢管件
台积电（南京）有限公司		316L不锈钢管道	梅塞尔特种气体（滁州）有限公司		316L BA 管道、管件
台塑工业（宁波有限公司）		316L不锈钢管道	京东方华灿光电股份有限公司-氢气站项目		316L BA管道
惠生工程（中国）有限公司		316L不锈钢管道	东方光源集团有限公司		316L/304L BA 管道 316L/304L 管件
重庆京东方光电科技有限公司		CDA化学品系统管道、管件 BA、EP 316L	西安隆基乐叶光伏科技有限公司		316L/304L BA 管道
重庆材料研究院有限公司		N04400、N06600 BA 精密管	京隆科技（苏州）有限公司		316L BA AP 管道及配件